

INSTRUCTION MANUAL



NR-LITE Net Radiometer

Revision: 8/06



Copyright © 1998-2006
Campbell Scientific, Inc.

Warranty and Assistance

The **NR-LITE NET RADIOMETER** is warranted by CAMPBELL SCIENTIFIC, INC. to be free from defects in materials and workmanship under normal use and service for twelve (12) months from date of shipment unless specified otherwise. Batteries have no warranty. CAMPBELL SCIENTIFIC, INC.'s obligation under this warranty is limited to repairing or replacing (at CAMPBELL SCIENTIFIC, INC.'s option) defective products. The customer shall assume all costs of removing, reinstalling, and shipping defective products to CAMPBELL SCIENTIFIC, INC. CAMPBELL SCIENTIFIC, INC. will return such products by surface carrier prepaid. This warranty shall not apply to any CAMPBELL SCIENTIFIC, INC. products which have been subjected to modification, misuse, neglect, accidents of nature, or shipping damage. This warranty is in lieu of all other warranties, expressed or implied, including warranties of merchantability or fitness for a particular purpose. CAMPBELL SCIENTIFIC, INC. is not liable for special, indirect, incidental, or consequential damages.

Products may not be returned without prior authorization. The following contact information is for US and International customers residing in countries served by Campbell Scientific, Inc. directly. Affiliate companies handle repairs for customers within their territories. Please visit www.campbellsci.com to determine which Campbell Scientific company serves your country. To obtain a Returned Materials Authorization (RMA), contact CAMPBELL SCIENTIFIC, INC., phone (435) 753-2342. After an applications engineer determines the nature of the problem, an RMA number will be issued. Please write this number clearly on the outside of the shipping container. CAMPBELL SCIENTIFIC's shipping address is:

CAMPBELL SCIENTIFIC, INC.

RMA#_____

815 West 1800 North

Logan, Utah 84321-1784

CAMPBELL SCIENTIFIC, INC. does not accept collect calls.

NR-LITE Table of Contents

PDF viewers note: These page numbers refer to the printed version of this document. Use the Adobe Acrobat® bookmarks tab for links to specific sections.

1. General Description	1
1.1 Electrical Properties.....	2
1.2 Spectral Properties.....	2
1.3 Directional/Cosine Response.....	3
1.4 Sensitivity to Wind Speed.....	4
2. Sensor Specifications	5
3. Installing the NR-LITE	6
4. Wiring	8
5. Datalogger Programming	9
5.1 Datalogger Input Range Codes.....	9
5.2 Calibration Factor.....	9
5.3 Example Programs.....	9
5.3.1 Example 1, CR10/10X Program without Wind Speed Correction..	9
5.3.2 Example 2, CR10/10X Program with Wind Speed Correction.....	10
6. Maintenance	12
7. Troubleshooting	12
7.1 Checking Sensor Operation.....	12
7.2 Radiometer produces no apparent output	13
7.3 Readings are not as expected.....	14

Figures

1. General View and Dimensions of NR-LITE	1
2. Electrical Circuit for the NR-LITE Net Radiometer.....	2
3. Approximate Spectral Sensitivity and Solar/F.I.R. Radiation	3
4. Cosine Response of a Typical Net Radiometer	4
5. NR-LITE Wind Sensitivity.....	5
6. NR-LITE Mounting Options	7
7. NR-Lite to Datalogger Connections	8

Tables

1. Datalogger Connections for Differential Measurement	8
2. Datalogger Connections for Single-Ended Measurement.....	8

NR-LITE Net Radiometer

The NR-LITE is a high-output thermopile sensor which measures the algebraic sum of incoming and outgoing all-wave radiation (i.e. both short-wave and long-wave components). Incoming radiation consists of direct (beam) and diffuse solar radiation plus long-wave irradiance from the sky. Outgoing radiation consists of reflected solar radiation plus the terrestrial long-wave component.

The NR-LITE is equipped with Teflon-coated sensor surfaces. This results in a robust design which gives very easy maintenance and good sensor stability. However, this design is slightly less accurate than the more traditional radiometers which use plastic domes.

1. General Description

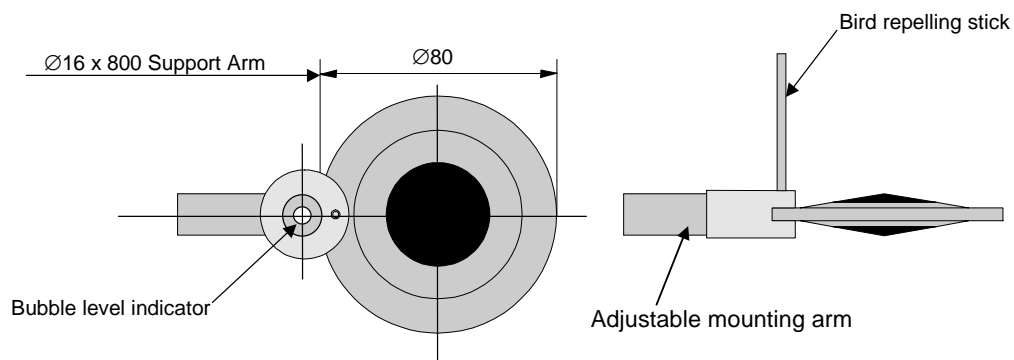

FIGURE 1. General View and Dimensions of NR-LITE

The NR-LITE is used for measuring solar and far infrared radiation balance. This balance is known as the net (total) radiation. Its upwards facing sensor measures the solar energy and far infra-red energy that is received from the entire hemisphere (180° field of view). Its downwards facing sensor measures the energy received from the surface of the soil. The two readings are automatically subtracted and the result converted to a single output signal. This output represents the net radiation, (which can be interpreted as meaning the radiative energy that is seen at the surface) and is expressed in Watts per square meter (W m^{-2}).

The NR-LITE is designed for continuous outside use. The sensor surfaces are coated with Teflon. This ensures good sensor stability, very long life and easy maintenance compared to the more usual radiometers fitted with plastic domes. However, it does have some disadvantages, particularly a higher sensitivity to wind speed with a subsequent lessening of accuracy. It is, though, possible to correct for the wind speed sensitivity if the sensor is installed in a system where wind speed is also being measured.

Although net radiometers are usually used in meteorology to measure radiation balance, the NR-LITE can also be used to measure indoor climate radiative stress.

1.1 Electrical Properties

The thermopile consists of a number of thermocouples connected in series, essentially providing a highly sensitive differential temperature sensor. The thermopile generates a voltage output – the sensor itself is passive, and so no power supply is required.

The upwards and downwards facing sensor surfaces are connected to the upper and lower thermopile junctions respectively, and so the sensor can measure the differential temperature. This temperature differential can be measured to a high accuracy (in the order of 0.001 degrees), and is proportional to the net radiation.

The thermopile determines the electrical characteristics of the instrument. Both upper and lower facing sensors have a field of view of 180 degrees, and their angular characteristics conform closely to the so-called ‘cosine’ response (see following sections).

The electrical sensitivity for the thermopile changes with temperature, and no nominal sensitivity value is available.

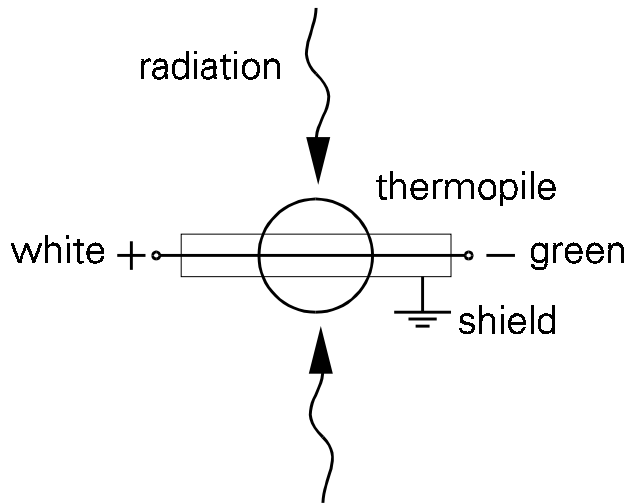

FIGURE 2. Electrical Circuit for the NR-LITE Net Radiometer

1.2 Spectral Properties

The spectral properties of the NR-LITE are determined by the Teflon surface of the sensors. An approximate spectral sensitivity response curve for the instrument combined with the spectrum of the sun under a clear sky, and the spectrum of outgoing far infra-red radiation (F.I.R.) is shown in Figure 3, below.

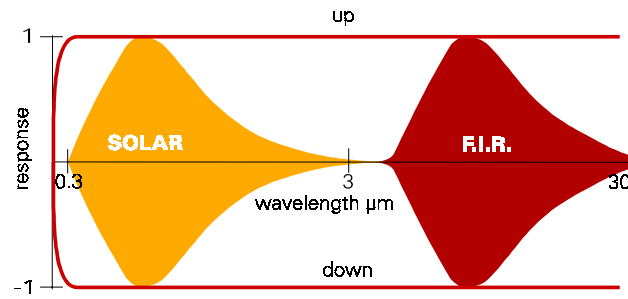

FIGURE 3. Approximate Spectral Sensitivity and Solar/F.I.R. Radiation

The upwards facing sensor is calibrated for solar radiation wavelengths. The following assumptions are made:

- It is assumed that the downwards facing sensor has the same sensitivity. However, since the two sensors may not be perfectly symmetrical, this assumption may not always be true, but any differences are small.
- It is also assumed that the NR-LITE's sensitivity is the same for both solar and infrared radiation.

1.3 Directional/Cosine Response

The measurement of the radiation falling on a surface (also known as irradiance or radiative flux) is based on two assumptions:

1. The sensor surface is spectrally black - i.e. that it absorbs all radiation from all wavelengths (see section above).
2. That it has a true field of view of 180°.

These two properties, taken together, with which the net radiometer needs to comply, are generally known as the 'cosine response'.

A perfect cosine response will show maximum sensitivity at an angle of incidence of zero degrees (perpendicular to the sensor surface) and zero sensitivity at an angle of incidence of 90 degrees (radiation passing over the sensor surface). At any angle between 0 and 90 degrees the sensitivity should be proportional to the cosine of the angle of incidence.

Figure 4 shows the behavior of a typical net radiometer. The vertical axis shows the deviation from ideal behavior, expressed in percentage deviation from the ideal value.



FIGURE 4. Cosine Response of a Typical Net Radiometer

1.4 Sensitivity to Wind Speed

The calibration of the NR-LITE is carried out at zero wind speed. At any other wind speed the sensitivity will decrease. It has been shown that this decrease in sensitivity is less than 1% of reading per meter per second wind speed, and the effect is essentially independent of the radiation level.

Net radiation readings can be corrected for wind speed sensitivity using the following equation, which was developed by Jerry Brotzge at the Oklahoma Climate Survey:

Wind Sensitivity equation for the NR-LITE:

$$\begin{aligned}
 Rn_{cor} &= Rn_{obs} & U < 5 \text{ m/s} \\
 Rn_{cor} &= Rn_{obs} * (1.0 + A * (U - 5.0)) & U > 5 \text{ m/s}
 \end{aligned}$$

Where,

- Rn_{cor} = Net radiation corrected for wind speed
- Rn_{obs} = Net radiation not corrected for wind speed
- U = Horizontal wind speed in m/s
- A = empirical constant derived from data = 0.021286

The following scatter plots illustrate the wind sensitivity for both the NR-LITE and CNR1 net radiometer models.

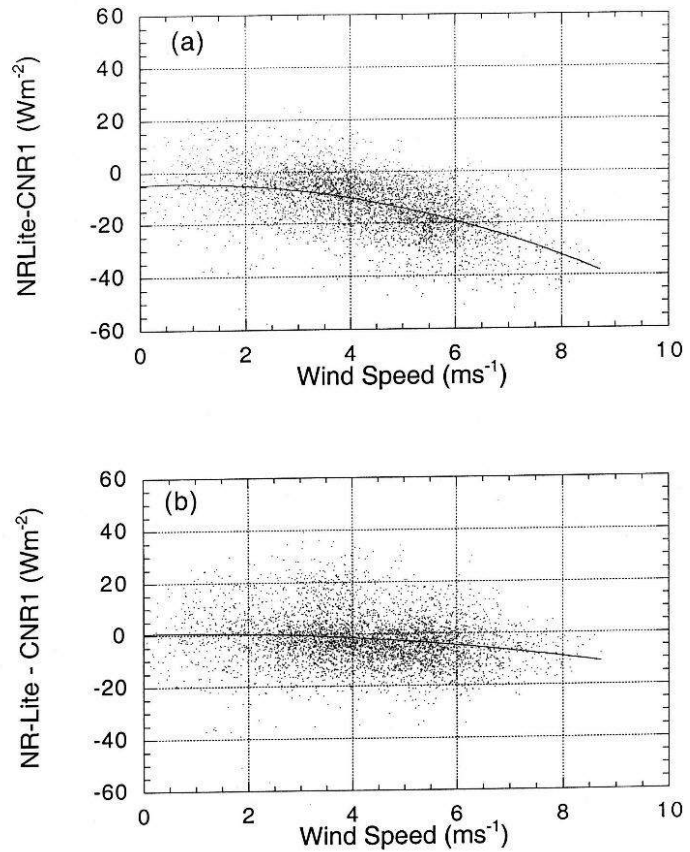

Fig. 10: Differences between the NR-Lite and CNR1 as a function of wind speed for daytime conditions during 7 May - 6 June, 1998. (a) No correction. (b) Eq. (4) applied as a correction.

FIGURE 5. NR-LITE Wind Sensitivity

2. Sensor Specifications

Spectral

Spectral range:	0.2 to 100 μm
Detector type:	Thermopile
Detector protection:	Teflon coating
Detector profile:	Conical

Directional

Directional error:	
(0 - 60° at 1000 W m^{-2}):	<30 W m^{-2}
Sensor asymmetry:	$\pm 5\%$ typical, ($\pm 10\%$ worst case).

Mechanical

Housing material:	Anodized aluminum
Cable material:	Polyurethane
Weight:	200 g
Cable length:	15 m (can be extended up to 100 m)
Physical Dimensions	
Sensor:	3.1" (8.0 cm) diameter
Support Arm:	0.6" (1.6 cm) diameter x 31.5" (80 cm) L
Weight:	23 oz (635 g)

Environmental

Working temperature:	-30 to +70°C
Temperature dependence:	0.12%/°C

3. Installing the NR-LITE

NOTE Screw in the ~2.5" long bird repellent stick, which is typically shipped with the calibration documentation.

Mount the sensor so that no shadow will be cast on it at any time of day from obstructions such as trees, buildings or the mast or structure on which it is mounted. In the northern hemisphere the instrument is normally oriented towards the South to avoid potential problems from shading. The downward facing sensor is representative (99%) for a circular area having a radius of ten times the height (10h).

To avoid shading effects and to promote spatial averaging the NR-LITE should be mounted at least 1.5 m above the ground surface. It is recommended that the NR-LITE be mounted to a separate vertical pipe at least 25' from any other mounting structures. PN 14264 mounting bracket is used to mount the NR-LITE directly to a vertical pipe, or to a UT108 Tower Mounting Bracket and Crossarm. Mount the sensor as follows:

1. Attach PN 14264 mounting bracket to the vertical mounting pipe, or UT018 crossarm using the hardware provided. The hole through PN 14264 has two different diameters to accommodate different models of sensors. The NR-LITE mounts through the larger diameter hole that extends half way through the bracket.
2. Feed the sensor cable through the larger diameter hole in the mounting bracket, followed by the mounting arm of the sensor. Tighten the two set screws just enough to secure the mounting arm position, but loose enough to be rotated.

NOTE Do not attempt to rotate the instrument using the sensor head or you may damage the sensor – use the mounting arm only.

3. Loosen the vertical adjustment screws on the back of the 14264 mounting bracket. Adjust the sensor mounting arm horizontally and vertically until the bubble level on the sensor head shows level. Tighten the adjustment screws to secure the position.

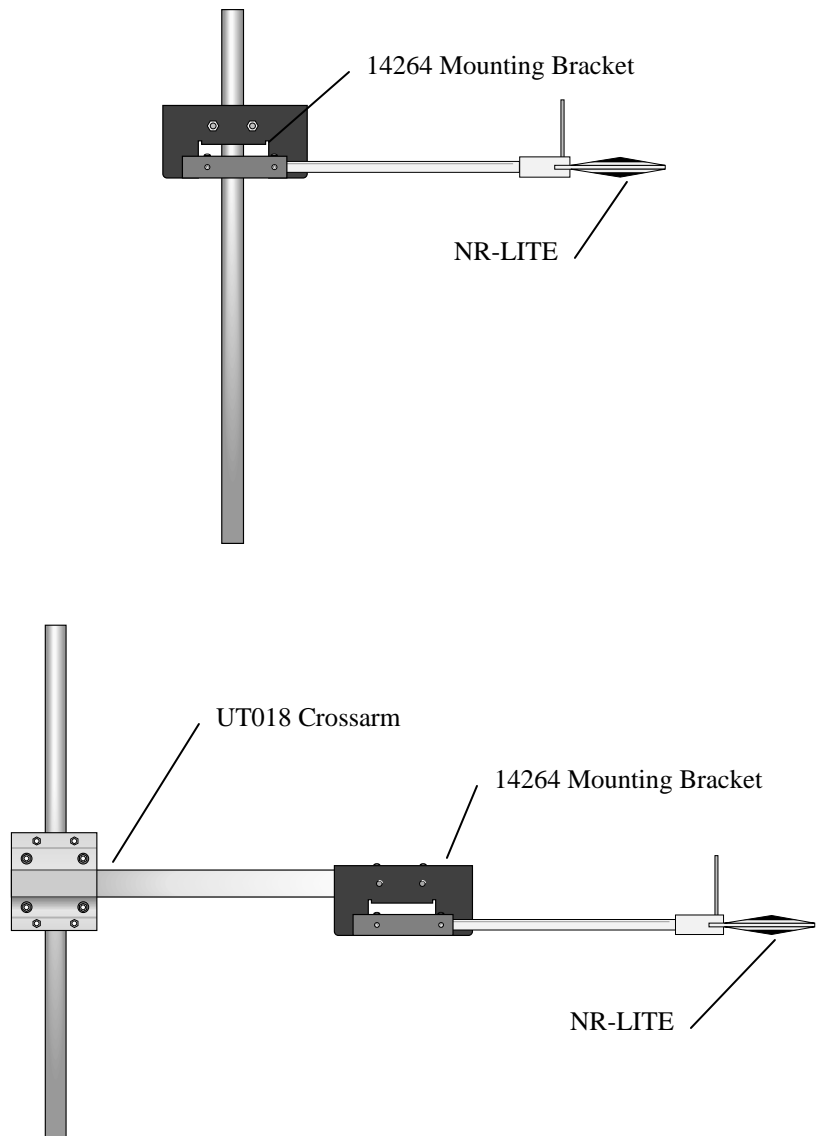

FIGURE 6. NR-LITE Mounting Options

4. Wiring

The NR-LITE can be measured with a differential or single-ended channel on the datalogger; a differential channel is recommended.

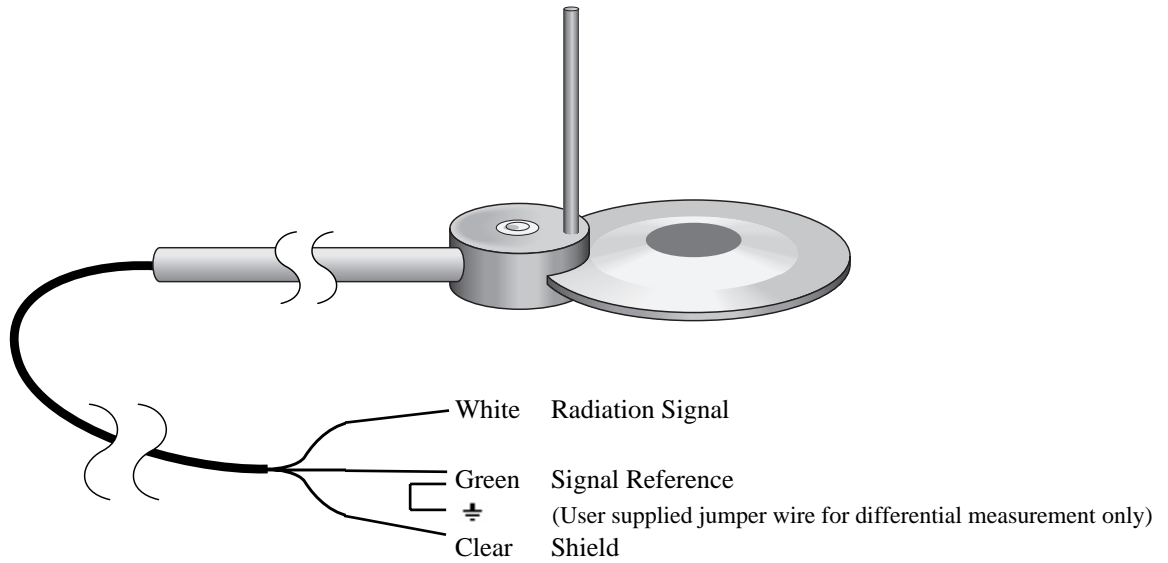

FIGURE 7. NR-Lite to Datalogger Connections

TABLE 1. Datalogger Connections for Differential Measurement

Function	Color	CR10X,CR510	CR23X	21X/CR7
Radiation Signal	White	Differential H	Differential H	Differential H
Signal Reference	Green	Differential L	Differential L	Differential L
	Jumper to	AG	⚡	⚡
Shield	Clear	G	⚡	⚡

TABLE 2. Datalogger Connections for Single-Ended Measurement

Function	Color	CR10X,CR510	CR23X	21X/CR7
Radiation Signal	White	S.E. Channel	S.E. Channel	S.E. Channel
Signal Reference	Green	AG	⚡	⚡
Shield	Clear	G	⚡	⚡

5. Datalogger Programming

The NR-LITE outputs a low-level voltage ranging from 0 to a maximum of about 15 mV. A differential voltage measurement (Instruction 2) is recommended because it has better noise rejection than a single-ended measurement. If a differential channel is not available, a single-ended measurement (Instruction 1) can be used. The acceptability of a single-ended measurement can be determined by simply comparing the results of single-ended and differential measurements made under the same conditions.

5.1 Datalogger Input Range Codes

Normally the 15 mV range for the 21X and CR7, the 25 mV range for the CR10(X) and CR500/CR510, and the 50 mV range for the CR23X are suitable.

The parameter code for the input range also specifies the measurement integration time. The slow or 60 Hz rejection integration gives a more noise-free reading. A fast integration takes less power and allows for faster throughput.

5.2 Calibration Factor

Each NR-LITE is provided with a 'Certificate of Calibration' by the manufacturer which shows the sensor serial number and a 'sensitivity' or calibration factor. This calibration factor, after conversion, is used in the datalogger program. Always cross check to ensure that the serial number of your NR-LITE and the number on the calibration certificate are identical. The serial number and sensitivity are also shown on a small label attached to the connecting arm near the head of the sensor itself.

The calibration factor provided by Kipp & Zonen is in units of $\mu\text{V}/(\text{W m}^{-2})$, which needs to be converted to units of $(\text{W m}^{-2})/\text{mV}$ for the multiplier parameter in the datalogger program. To convert the units, divide the calibration factor into 1000. For example, if the calibration factor is 15.8 $\mu\text{V}/(\text{W m}^{-2})$, the multiplier is:

$$1000/15.8 = 63.29 (\text{W m}^{-2})/\text{mV}$$

5.3 Example Programs

5.3.1 Example 1, CR10(X) Program without Wind Speed Correction

Shown below is an example program written for the CR10(X) datalogger. The datalogger measures the output from the sensor every 60 seconds and outputs the average net radiation every hour.

The calibration factor used will only apply for one specific sensor. A new value will need to be calculated for every different sensor based on the certificate of calibration for that sensor (see above).

Wiring for Example 1

Color	Function	Example CR10X Program Channels Used
White	Radiation Signal	1H
Green	Signal Reference	1L
Jumpered to		AG
Clear	Shield	G

```

;{CR10X}
;
*Table 1 Program
01: 60      Execution Interval (seconds)
1: Volt (DIFF) (P2)
  1: 1      Reps
  2: 3**    25 mV Slow Range      ;range code for CR10(X) datalogger
  3: 1*     DIFF Channel
  4: 1*     Loc [ Net_rad ]
  5: 63.29  Mult                  ;Multiplier for specific sensor
  6: 0.0    Offset                ;in units of (W m-2)/mV (see above)
2: If time is (P92)
  1: 0      Minutes (Seconds --) into a
  2: 60     Interval (same units as above)
  3: 10     Set Output Flag High (Flag 0)
3: Real Time (P77)
  1: 110    Day,Hour/Minute (midnight = 0000)
4: Average (P71)
  1: 1      Reps
  2: 1      Loc [ Net_rad ]
    
```

5.3.2 Example 2, CR10X Program with Wind Speed Correction

Example 2 measures the NR-LITE using a Single-Ended input and Instruction 1. The program also measures wind speed and applies the correction factor as described in Section 1.4. Average net radiation and wind speed are output every hour.

Wiring for Example 2

Color	Function	Example CR10X Program Channels Used
White	Radiation Signal	S.E. Channel 1
Green	Signal Reference	AG
Clear	Shield	G

```

;{CR10X}
;
*Table 1 Program
  01: 60      Execution Interval (seconds)

;measure 05103 wind speed

1: Pulse (P3)
  1: 1      Reps
  2: 1      Pulse Channel 1
  3: 21     Low Level AC, Output Hz
  4: 1      Loc [ Wspd_m_s ]
  5: .0980  Mult
  6: 0      Offset

;measure NR-LITE net radiation

2: Volt (SE) (P1)
  1: 1      Reps
  2: 3**    25 mV Slow Range
  3: 1*     SE Channel
  4: 2*     Loc [ Rn_obs  ]
  5: 63.29  Mult
  6: 0      Offset
                                     ;Multiplier for specific sensor
                                     ;in units of (W m-2)/mV (see above)

;apply wind speed correction factor
;Rn,cor = Rn,obs*(1.0+0.021286*(U-5.0)) when U > 5 m/s

3: If (X<=>F) (P89)
  1: 1      X Loc [ Wspd_m_s ]
  2: 3      >=
  3: 5      F
  4: 30     Then Do

  4: Z=X+F (P34)
    1: 1      X Loc [ Wspd_m_s ]
    2: -5     F
    3: 24     Z Loc [ scratch_1 ]

  5: Z=X*F (P37)
    1: 24     X Loc [ scratch_1 ]
    2: .021286 F
    3: 25     Z Loc [ scratch_2 ]

  6: Z=X+F (P34)
    1: 25     X Loc [ scratch_2 ]
    2: 1      F
    3: 26     Z Loc [ scratch_3 ]

  7: Z=X*Y (P36)
    1: 26     X Loc [ scratch_3 ]
    2: 2      Y Loc [ Rn_obs  ]
    3: 3      Z Loc [ Rn_cor  ]

8: Else (P94)

```

```

9: Z=X (P31)
  1: 2      X Loc [ Rn_obs  ]
  2: 3      Z Loc [ Rn_cor  ]

10: End (P95)

11: If time is (P92)
  1: 0      Minutes (Seconds --) into a
  2: 60     Interval (same units as above)
  3: 10     Set Output Flag High (Flag 0)

12: Real Time (P77)
  1: 1220   Year,Day,Hour/Minute (midnight = 2400)

13: Average (P71)
  1: 1      Reps
  2: 3      Loc [ Rn_cor  ]

14: Average (P71)
  1: 1      Reps
  2: 1      Loc [ Wspd_m_s ]
    
```

- * Proper entries will vary with program and input channel assignments.
- ** 25 mV range for CR10(X) and CR510, the 50 mV range for CR23X, and the 15 mV range for 21X and CR7.

6. Maintenance

The radiometer is an ‘all weather’ instrument and is very stable, but should be handled with care. It requires little periodic maintenance, apart from cleaning the sensor surfaces carefully with a soft cloth using water or alcohol.

The NR-LITE should be recalibrated every two years. Contact CSI for an RMA number before returning the sensor for recalibration.

7. Troubleshooting

7.1 Checking Sensor Operation

To effectively check the instrument’s operation, you will need:

1. The NR-LITE itself
2. A voltmeter, range 0 to 50 mV, with an input impedance greater than 5000 Ohms
3. A light source
4. A table or bench

Position the radiometer so that its downward facing sensor is about 10 mm (0.4”) above a flat surface (table or bench), and the upwards facing sensor is facing the light source (lamp). Do not touch the sensor head itself, as this will

introduce thermal shocks. Hold the instrument only by its mounting arm at all times.

Follow the procedure outlined below:

- Connect the NR-LITE wires to the voltmeter. Connect the white wire to the positive lead and the green wire to the negative lead.
- Select the most sensitive range on the voltmeter.
- With the lamp switched off, read the sensor output signal – allow a minute or so for the signal to fully stabilize.
- Switch on the lamp. The sensor should now produce a higher positive reading.
- Turn the lamp off again, when the signal should slowly return to its original level, proving the sensor's sensitivity to light.
- Turn the sensor upside down. The signal value should reverse in sign (i.e. a +10 mV signal should become a –10 mV signal). Don't worry if the two values are not exactly the same (up to 10% difference) as the sensor profiles can vary. After completing this test, return the sensor to its original orientation and let it stabilize.
- Put your hand over the upper sensor. Assuming that your hand is at a higher temperature than the sensor the positive reading should increase. Conversely, if the sensor is warmer than your hand the reading will decrease.
- Check the radiometer's sensitivity to thermal shocks by touching the edge of the sensor (the blank metal) with your hand for some seconds. The resultant shock will result in a signal drift, or a zero offset that will take some time to settle back to zero.
- Adjust the range of the voltmeter so that the expected full-scale output of the radiometer is about the same as the range of the voltmeter. A (theoretical) way to calculate the maximum expected output for normal meteorological applications is shown below:

Max. expected radiation +1500 W m⁻²

Min. radiation –200 W m⁻²

Sensitivity of the net radiometer 10 μV/(W m⁻²)

Expected output range of the radiometer is (1500+200) x 10 =
1700 x 10 = 17.0 mV or 0.017 V.

7.2 Radiometer produces no apparent output

If your net radiometer does not appear to be working at all, do the following checks:

- Check the instrument's sensitivity to radiation, following the procedure shown in Section 7.1.

- If this appears to produce no results, measure the impedance of the sensor across the white and green wires. The impedance reading should be close to 2.3Ω . If it is virtually zero, a short circuit is indicated. If it is 'infinite', the thermopile is blown.

7.3 Readings are not as expected

- Under full sunlight the expected radiation value is about 1000 W m^{-2} . Under lamps it may be greater. For indoor climate studies, smaller values are to be expected unless solar radiation is present. A typical value for a room when facing a wall and a relatively cold window is 50 W m^{-2} .
- Are you using the correct calibration factor? Note that this factor is unique for each individual sensor as noted on the calibration certificate provided with that sensor. Did you convert the factor to the correct value for the datalogger program? (See Section 5, above).
- Check the datalogger program for errors.

If you cannot resolve your problems, please contact Campbell Scientific for further advice.

Campbell Scientific Companies

Campbell Scientific, Inc. (CSI)

815 West 1800 North
Logan, Utah 84321
UNITED STATES
www.campbellsci.com
info@campbellsci.com

Campbell Scientific Africa Pty. Ltd. (CSAf)

PO Box 2450
Somerset West 7129
SOUTH AFRICA
www.csafrica.co.za
cleroux@csafrica.co.za

Campbell Scientific Australia Pty. Ltd. (CSA)

PO Box 444
Thuringowa Central
QLD 4812 AUSTRALIA
www.campbellsci.com.au
info@campbellsci.com.au

Campbell Scientific do Brazil Ltda. (CSB)

Rua Luisa Crapsi Orsi, 15 Butantã
CEP: 005543-000 São Paulo SP BRAZIL
www.campbellsci.com.br
suporte@campbellsci.com.br

Campbell Scientific Canada Corp. (CSC)

11564 - 149th Street NW
Edmonton, Alberta T5M 1W7
CANADA
www.campbellsci.ca
dataloggers@campbellsci.ca

Campbell Scientific Ltd. (CSL)

Campbell Park
80 Hathern Road
Shepshed, Loughborough LE12 9GX
UNITED KINGDOM
www.campbellsci.co.uk
sales@campbellsci.co.uk

Campbell Scientific Ltd. (France)

Miniparc du Verger - Bat. H
1, rue de Terre Neuve - Les Ulis
91967 COURTABOEUF CEDEX
FRANCE
www.campbellsci.fr
campbell.scientific@wanadoo.fr

Campbell Scientific Spain, S. L.

Psg. Font 14, local 8
08013 Barcelona
SPAIN
www.campbellsci.es
info@campbellsci.es