

INSTRUCTION MANUAL



Model 109SS Temperature Probe

9/08



Warranty and Assistance

The **MODEL 109SS TEMPERATURE PROBE FOR HARSH ENVIRONMENTS** is warranted by CAMPBELL SCIENTIFIC, INC. to be free from defects in materials and workmanship under normal use and service for twelve (12) months from date of shipment unless specified otherwise. Batteries have no warranty. CAMPBELL SCIENTIFIC, INC.'s obligation under this warranty is limited to repairing or replacing (at CAMPBELL SCIENTIFIC, INC.'s option) defective products. The customer shall assume all costs of removing, reinstalling, and shipping defective products to CAMPBELL SCIENTIFIC, INC. CAMPBELL SCIENTIFIC, INC. will return such products by surface carrier prepaid. This warranty shall not apply to any CAMPBELL SCIENTIFIC, INC. products which have been subjected to modification, misuse, neglect, accidents of nature, or shipping damage. This warranty is in lieu of all other warranties, expressed or implied, including warranties of merchantability or fitness for a particular purpose. CAMPBELL SCIENTIFIC, INC. is not liable for special, indirect, incidental, or consequential damages.

Products may not be returned without prior authorization. The following contact information is for US and International customers residing in countries served by Campbell Scientific, Inc. directly. Affiliate companies handle repairs for customers within their territories. Please visit www.campbellsci.com to determine which Campbell Scientific company serves your country.

To obtain a Returned Materials Authorization (RMA), contact CAMPBELL SCIENTIFIC, INC., phone (435) 753-2342. After an applications engineer determines the nature of the problem, an RMA number will be issued. Please write this number clearly on the outside of the shipping container. CAMPBELL SCIENTIFIC's shipping address is:

CAMPBELL SCIENTIFIC, INC.

RMA#_____

815 West 1800 North

Logan, Utah 84321-1784

For all returns, the customer must fill out a "Declaration of Hazardous Material and Decontamination" form and comply with the requirements specified in it. The form is available from our website at www.campbellsci.com/repair. A completed form must be either emailed to shanna@campbellsci.com or faxed to 435-750-9579. Campbell Scientific will not process any returns until we receive this form. If the form is not received within three days of product receipt or is incomplete, the product will be returned to the customer at the customer's expense. Campbell Scientific reserves the right to refuse service on products that were exposed to contaminants that may cause health or safety concerns for our employees.

CAMPBELL SCIENTIFIC, INC. does not accept collect calls.

109SS Table of Contents

PDF viewers note: These page numbers refer to the printed version of this document. Use the Adobe Acrobat® bookmarks tab for links to specific sections.

1. General	1
1.1 Specifications.....	2
2. Accuracy	3
3. Installation and Wiring	4
3.1 Burial	4
3.2 Submersion	4
4. Wiring	4
5. Programming	4
5.1 CRBasic	5
5.1.1 CRBasic Examples.....	5
5.1.1.1 Sample Program for CR200 Series Datalogger.....	6
5.1.1.2 Example 2. Sample Program for CR1000 Datalogger	6
5.1.1.3 Sample Program for CR5000	7
5.2 Edlog.....	7
5.2.1 Example Edlog Program	7
5.3 Electrical Noisy Environments	9
5.4 Long Lead Lengths.....	9
6. Measurement Details	10
7. Maintenance and Calibration	11
8. Troubleshooting	11

Figures

1-1. 109SS Temperature Probe.....	1
2-1. Steinhart and Hart.....	3
2-2. Possible Errors.....	3
6-1. 109SS Thermistor Probe Schematic.....	10

Tables

4-1. Connections to Campbell Scientific Dataloggers.....	4
5-1. Wiring for Example Programs	5
5-2. Wiring for Example Program.....	7

Model 109SS Temperature Probe

1. General

The -L portion of this probe's model number indicates the probe has a user-specified lead length. For readability purposes, the probe will be referred to as the 109SS throughout this document.

The 109SS consists of a thermistor encased in a stainless-steel sheath. The rugged stainless-steel sheath protects the thermistor allowing the 109SS to be buried or submerged in harsh, corrosive environments. It also has a fast time response. This probe measures temperature from -40°C to $+70^{\circ}\text{C}$. The thermistor can survive temperatures up to 100°C , but the overmolded joint and cable should not be exposed to temperatures greater than $+70^{\circ}\text{C}$ (see Figure 1-1).

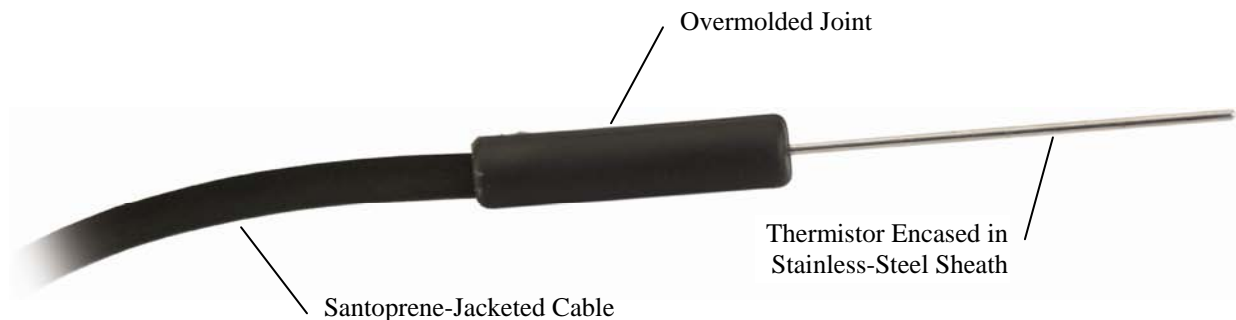

FIGURE 1-1. 109SS Temperature Probe

The 109SS probe is typically used with the CR200-series, CR800, CR850, CR1000, and CR3000 dataloggers which have a special instruction for measuring it. The probe can also be measured with other Campbell Scientific dataloggers using generic measurement instructions.

The 109SS ships with:

- (1) Resource CD

1.1 Specifications

Temperature Range: -40° to +70°C

Survival Range: -50° to +100°C (thermistor); -50°C to +70°C (overmolded joint and cable)

Thermistor Interchangeability Tolerance:

<u>Temperature</u>	<u>Tolerance</u>
-40°C	±0.6°C
0°C	±0.38°C
25°C	±0.1°C
50°C	±0.3°C
70°C	±0.45°C

Time Constant:

<u>Fluid</u>	<u>τ</u>
Still Air	31 seconds
Air @ 3 meter/second	7.5 seconds
Antifreeze/Water Rolling	0.5 seconds

Water submersion depth: 50 feet (21 psi)

Linearization Error: Steinhart & Hart equation; maximum error is 0.02°C at -40°C.

Maximum Lead Length: 1000 ft

Other Information:

Thermistor: BetaTherm - Micro-BetaCHIP Probe 10K3MCD1 0.018" diameter, 10Kohms at 25 C

Probe:

stainless steel sheath 0.063 inch (0.16 cm) diameter, 2.3 inch (5.84 cm) length
overmolded joint 0.40 inch (1.02 cm) diameter, 1.67 inch (4.24 cm) length

Cable: Santoprene 0.220 inch diameter

Cable/probe connection: "ATUM" heat shrink, "Macromelt" overmolded joint

Weight: 0.2 lbs/10 1/2 ft cable

NOTE

The black outer jacket of the cable is Santoprene® rubber. This compound was chosen for its resistance to temperature extremes, moisture, and UV degradation. However, this jacket will support combustion in air. It is rated as slow burning when tested according to U.L. 94 H.B. and will pass FMVSS302. Local fire codes may preclude its use inside buildings.

2. Accuracy

The overall probe accuracy is a combination of the thermistor's interchangeability specification and the accuracy of the bridge resistor. The Steinhart and Hart equation used to calculate temperature has a negligible error (Figure 2-1). In a "worst case" the errors add to an accuracy of $\pm 0.6^{\circ}\text{C}$ over the range of -40° to 70°C and $\pm 0.49^{\circ}\text{C}$ over the range of -20°C to 70°C . The major error component is the interchangeability specification (tolerance) of the thermistor. The bridge resistor has a 0.1% tolerance with a 10 ppm temperature coefficient. Figure 2-2 shows the possible worst case probe and measurement errors.

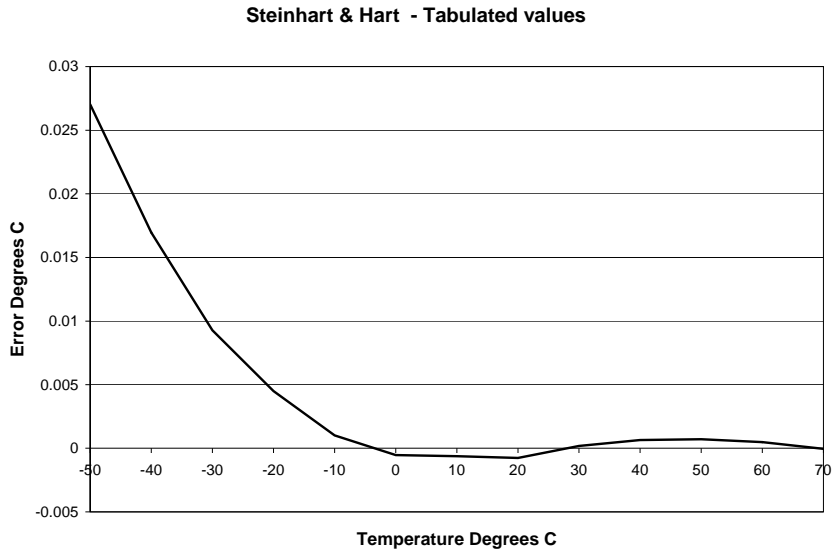

FIGURE 2-1. Steinhart and Hart

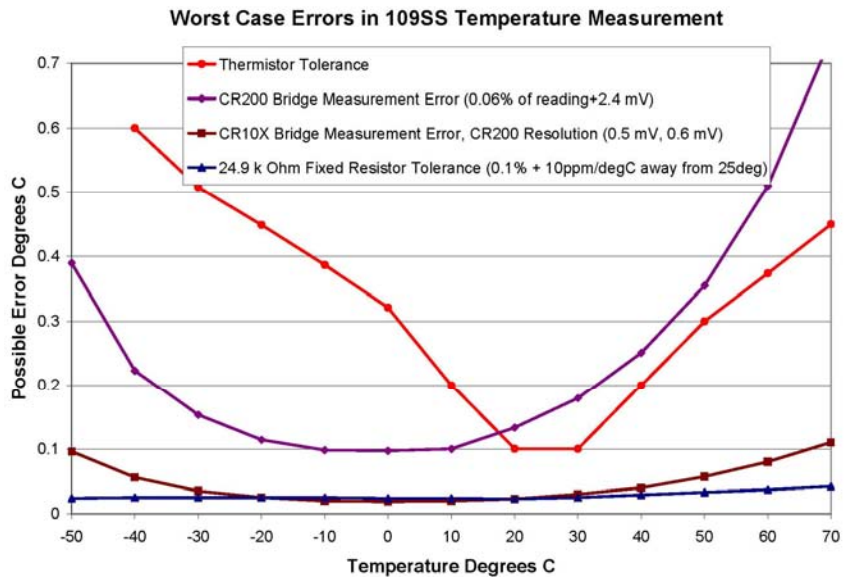

FIGURE 2-2. Possible Errors

3. Installation and Wiring

3.1 Burial

The 109SS is suitable for shallow burial only. It should be placed horizontally at the desired depth to avoid thermal conduction from the surface to the thermistor. Placement of the cable inside a rugged conduit may be advisable for long cable runs, especially in locations subject to digging, mowing, traffic, use of power tools, or lightning strikes.

3.2 Submersion

The 109SS can be submerged to 50 ft. Please note that the 109SS is not weighted. Therefore, the installer should either add a weighting system or secure the probe to a fixed or submerged object such as a piling.

4. Wiring

Connections to Campbell Scientific dataloggers are given in Table 4-1. Temperature is measured with one Single-Ended input channel and a Voltage Excitation channel. Multiple probes can be connected to the same excitation channel (the number of probes per excitation channel is physically limited by the number of lead wires that can be inserted into a single voltage excitation terminal, approximately six).

TABLE 4-1. Connections to Campbell Scientific Dataloggers				
Color	Description	CR200 CR800 CR850 CR3000 CR1000	CR510 CR500 CR10(X)	CR5000 21X CR7 CR23X
Black	Excitation	Switched Voltage Excitation	Switched Voltage Excitation	Switched Voltage Excitation
Red	Temperature Signal	Single-Ended Input	Single-Ended Input	Single-Ended Input
Purple	Signal Ground	⏏	AG	⏏
Clear	Shield	⏏	G	⏏

5. Programming

NOTE

This section is for users who write their own datalogger programs. A datalogger program to measure this sensor can be generated using Campbell Scientific's Short Cut Program Builder software. You do not need to read this section to use Short Cut.

The datalogger is programmed using either CRBasic or Edlog. Dataloggers that use CRBasic include our CR200-series, CR800, CR850, CR1000, CR3000, CR5000, and CR9000(X); see Section 5.1. Dataloggers that use Edlog include our CR10, CR10(X), CR23X, and CR7; refer to Section 5.2. CRBasic and Edlog are included in our LoggerNet, PC400, and RTDAQ software.

If applicable, please read “Section 5.3—Electrical Noisy Environments” and “Section 5.4—Long Lead Lengths” prior to programming your datalogger. Measurement details are provided in Section 6.

5.1 CRBasic

In the CR200-series, CR800, CR850, CR1000, and CR3000 dataloggers, Instruction Therm109 is used to measure temperature. Therm109 provides excitation, makes a single ended voltage measurement, and calculates temperature.

The Therm109 instruction has the following form:

Therm109 (Dest, Repetitions, SE Chan, Ex Chan, Multiplier, Offset)

A multiplier of 1.0 and an offset of 0.0 yields temperature in Celsius. For Fahrenheit, use a multiplier of 1.8 and an offset of 32. Sections 5.1.1.1 and 5.1.1.2 provide example programs that use the Therm109 instruction.

The CR5000 and CR9000(X) use the BrHalf instruction to read the 109SS’s resistance. The Steinhart-Hart equation is entered as an expression to convert the resistance to degrees Celsius (see Section 5.1.1.3).

5.1.1 CRBasic Examples

TABLE 5-1. Wiring for Example Programs		
Color	Description	CR200 CR1000 CR5000
Black	Excitation	EX1 or VX1
Red	Signal	SE1
Purple	Signal Ground	⊥
Clear	Shield	⊥

5.1.1.1 Sample Program for CR200 Series Datalogger

```
'CR200 Series Datalogger

'This example program measures a single 109SS Thermistor Probe
'once a second and stores the average temperature every 10 minutes.

'Declare the variable for the temperature measurement
Public Air_Temp

'Define a data table for 10 minute averages:
DataTable (AvgTemp,1,1000)
    DataInterval (0,10,min)
    Average (1,Air_Temp,0)
EndTable

BeginProg
    Scan (1 ,sec)
        'Measure the temperature:
        Therm109 (Air_Temp,1,1,Ex1,1.0,0)
        'Call the data table:
        CallTable AvgTemp
    NextScan
EndProg
```

5.1.1.2 Example 2. Sample Program for CR1000 Datalogger

```
'CR1000

'Declare Variables and Units
Public T109_C

Units T109_C=Deg C

'Define Data Tables
DataTable(Table1,True,-1)
    DataInterval(0,10,Min,10)
    Average(1,T109_C,FP2,False)
EndTable

'Main Program
BeginProg
    Scan(1,Sec,1,0)
        'Default Datalogger Battery Voltage measurement Batt_Volt:
        '109SS Temperature Probe measurement T109_C:
        Therm109(T109_C,1,1,1,0,_60Hz,1.0,0.0)
        'Call Data Tables and Store Data
        CallTable(Table1)
    NextScan
EndProg
```

5.1.1.3 Sample Program for CR5000

```
'CR5000

'This example program measures a single 109 Thermistor probe
'once a second and stores the average temperature every 10 minutes.

'Declare the variable for the temperature.
Public Air_Temp
'Declare variables for the raw measurement, thermistor resistance, and ln(resistance):
Dim V_Vx, Rtherm, lnRt

'Define a data table for 10 minute averages:
DataTable (AvgTemp,1,1000)
    DataInterval (0,10,min,10)
    Average (1,Air_Temp,IEEE4,0)
EndTable

BeginProg
    Scan (1 ,sec,5,0)
        'Measure the 109 probe. The result is V/Vx:
        BrHalf (V_Vx,1,mV5000,3,Vx1,1,5000,True ,0,_60Hz,1.0,0)
        'Calculate resistance:
        RTherm=24900*(1/V_Vx-1)
        'Calculate the natural log of the resistance:
        lnRt=Log(Rtherm)
        'Apply the Steinhart and Hart equation and convert to degrees C in one step:
        Air_Temp=1/(1.129241e-3+2.341077e-4*lnRt+8.775468e-8*(lnRt^3))-273.15
        'Call the data table:
        CallTable AvgTemp
    NextScan
EndProg
```

5.2 Edlog

In Edlog, Instruction 5 is typically used to measure the 109SS resistance. Instruction 55 is used to apply the Steinhart and Hart equation. Instruction 55 does not allow entering the coefficients with scientific notation. In order to use this instruction with as much resolution as possible, the ln resistance term is pre scaled by 10^{-3} . This allows the first order coefficient (B) to be multiplied by 10^3 , and the 3rd order coefficient (C) to be multiplied by 10^9 (see Section 5.2.1).

5.2.1 Example Edlog Program

Color	Description	CR10X
Black	Excitation	E1
Red	Signal	SE1
Purple	Signal Ground	AG
Clear	Shield	G

Example Program for CR10X

```

;{CR10X}
;
*Table 1 Program
01: 1          Execution Interval (seconds)

1: AC Half Bridge (P5)
1: 1          Reps
2: 25         2500 mV 60 Hz Rejection Range
3: 1          SE Channel
4: 1          Excite all reps w/Exchan 1
5: 2500       mV Excitation
6: 1          Loc [ V_Vx   ]
7: 1.0        Mult
8: 0.0        Offset

2: Z=1/X (P42)
1: 1          X Loc [ V_Vx   ]
2: 2          Z Loc [ Vx_V   ]

3: Z=X+F (P34)
1: 2          X Loc [ Vx_V   ]
2: -1         F
3: 3          Z Loc [ Vx_V_1 ]

4: Z=X*F (P37)
1: 3          X Loc [ Vx_V_1 ]
2: 24900      F
3: 4          Z Loc [ Rtherm ]

5: Z=LN(X) (P40)
1: 4          X Loc [ Rtherm ]
2: 5          Z Loc [ lnRt   ]

6: Z=X*F (P37)
1: 5          X Loc [ lnRt   ]
2: .001       F
3: 6          Z Loc [ Scal_lnRt ]

7: Polynomial (P55)
1: 1          Reps
2: 6          X Loc [ Scal_lnRt ]
3: 7          F(X) Loc [ 1_Tk   ]
4: .001129    C0
5: .234108    C1
6: 0.0        C2
7: 87.7547    C3
8: 0.0        C4
9: 0.0        C5

8: Z=1/X (P42)
1: 7          X Loc [ 1_Tk   ]
2: 8          Z Loc [ Tk     ]

```

```

9: Z=X+F (P34)
  1: 8      X Loc [ Tk      ]
  2: -273.15 F
  3: 9      Z Loc [ Air_Temp ]

10: If time is (P92)
  1: 0      Minutes (Seconds --) into a
  2: 10     Interval (same units as above)
  3: 10     Set Output Flag High (Flag 0)

11: Real Time (P77)
  1: 110    Day,Hour/Minute (midnight = 0000)

12: Average (P71)
  1: 1      Reps
  2: 9      Loc [ Air_Temp ]

*Table 2 Program
  02: 0.0000 Execution Interval (seconds)

*Table 3 Subroutines

End Program

```

5.3 Electrical Noisy Environments

AC power lines, pumps, and motors, can be the source of electrical noise. If the 109SS probe or datalogger is located in an electrically noisy environment, the 109SS probe should be measured with the 60 or 50 Hz rejection option as shown in the examples in Section 5.1.1.2 and Section 5.2.1.

5.4 Long Lead Lengths

Additional settling time may be required for lead lengths longer than 300 feet, where settling time is the delay before the measurement is made.

For the CR200-series, CR800, CR850, CR1000, and CR3000, the 60 and 50 Hz integration options include a 3 ms settling time; longer settling times can be entered into the Settling Time parameter. The example Therm109 instruction listed below has a 20 mSec (20000 μ Sec) delay:

```

'Therm109 ( Dest, Reps, SEChan, ExChan, SettlingTime, Integ, Mult, Offset )
Therm109(T109_C,1,1,1,20000,_60Hz,1.0,0.0)

```

In Edlog, use the DC Half Bridge instruction (P4) with a 20 millisecond delay as shown below. Use P4 in place of P5 in Section 5.2.1 (the instructions that follow P5 to convert the measurement result to temperature are still required).

1: Excite-Delay (SE) (P4)		
1:	1	Reps
2:	25	2500 mV 60 Hz Rejection Range (Delay must be zero)
3:	1	SE Channel
4:	1	Excite all reps w/Exchan 1
5:	2	Delay (0.01 sec units)
6:	2500	mV Excitation
7:	3	Loc [V_Vx]
8:	.0004	Multiplier
9:	0.0	Offset

6. Measurement Details

Understanding the details in this section are not necessary for general operation of the 109SS Probe with CSI's dataloggers.

The Therm109 Instruction outputs a 2500 mV excitation and measures the voltage across the 24.9 K resistor (Figure 6-1). The thermistor resistance changes with temperature.

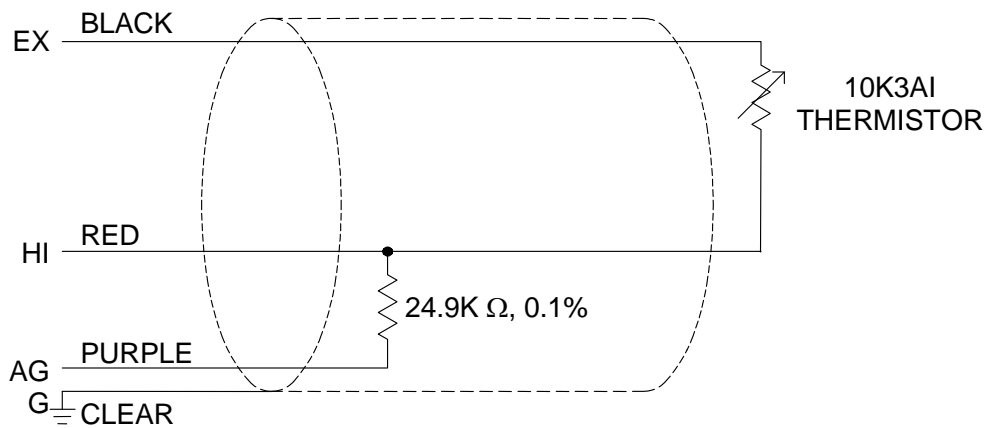

FIGURE 6-1. 109SS Thermistor Probe Schematic

The measured voltage, V, is:

$$V = V_{EX} \frac{24,900}{24,900 + R_t}$$

Where V_{EX} is the excitation voltage, 24,900 ohms is the resistance of the fixed resistor and R_t is the resistance of the thermistor

The resistance of the thermistor is:

$$R_t = 24,900 \left(\frac{V_{EX}}{V} - 1 \right)$$

The Steinhart and Hart equation is used to calculate temperature from Resistance:

$$T_K = \frac{1}{A + B \ln(R_T) + C(\ln(R_T))^3}$$

Where T_K is the temperature in Kelvin. The Steinhart and Hart coefficients used in the Therm109 instruction are:

$$A = 1.129241 \times 10^{-3}$$

$$B = 2.341077 \times 10^{-4}$$

$$C = 8.775468 \times 10^{-8}$$

7. Maintenance and Calibration

The 109SS Probe requires minimal maintenance. Periodically check cabling for proper connections, signs of damage, and possible moisture intrusion. For all factory repairs and recalibrations, customers must get a returned materials authorization (RMA). Customers must also properly fill out a “Declaration of Hazardous Material and Decontamination” form, and comply with the requirements specified in it. Refer to the “Warranty and Assistance” page for more information.

8. Troubleshooting

Symptom: Temperature is NAN, -INF, -9999, -273

Verify the red wire is connected to the correct Single-Ended analog input channel as specified by the measurement instruction, the black wire is connected to the switched excitation channel as specified by the measurement instruction, and the purple wire is connected to datalogger ground.

Symptom: Incorrect Temperature

Verify the multiplier and offset parameters are correct for the desired units (Section 5). Check the cable for signs of damage and possible moisture intrusion.

NOTE

For all factory repairs, customers must get an RMA. Customers must also properly fill out a “Declaration of Hazardous Material and Decontamination” form and comply with the requirements specified in it. Refer to the “Warranty and Assistance” page for more information.

Symptom: Unstable Temperature

Try using the 60 or 50 Hz integration options, and/or increasing the settling time as described in Sections 8 and 9. Make sure the clear shield wire is connected to datalogger ground, and the datalogger is properly grounded.

Campbell Scientific Companies

Campbell Scientific, Inc. (CSI)

815 West 1800 North
Logan, Utah 84321
UNITED STATES
www.campbellsci.com
info@campbellsci.com

Campbell Scientific Africa Pty. Ltd. (CSAf)

PO Box 2450
Somerset West 7129
SOUTH AFRICA
www.csafrica.co.za
cleroux@csafrica.co.za

Campbell Scientific Australia Pty. Ltd. (CSA)

PO Box 444
Thuringowa Central
QLD 4812 AUSTRALIA
www.campbellsci.com.au
info@campbellsci.com.au

Campbell Scientific do Brazil Ltda. (CSB)

Rua Luisa Crapsi Orsi, 15 Butantã
CEP: 005543-000 São Paulo SP BRAZIL
www.campbellsci.com.br
suporte@campbellsci.com.br

Campbell Scientific Canada Corp. (CSC)

11564 - 149th Street NW
Edmonton, Alberta T5M 1W7
CANADA
www.campbellsci.ca
dataloggers@campbellsci.ca

Campbell Scientific Ltd. (CSL)

Campbell Park
80 Hathern Road
Shepshed, Loughborough LE12 9GX
UNITED KINGDOM
www.campbellsci.co.uk
sales@campbellsci.co.uk

Campbell Scientific Ltd. (France)

Miniparc du Verger - Bat. H
1, rue de Terre Neuve - Les Ulis
91967 COURTABOEUF CEDEX
FRANCE
www.campbellsci.fr
info@campbellsci.fr

Campbell Scientific Spain, S. L.

Psg. Font 14, local 8
08013 Barcelona
SPAIN
www.campbellsci.es
info@campbellsci.es